

**2 PIECES BALL VALVE PN16/40 FLANGED JC RANGE
LONG PATTERN (DIN 3202-1 F1)**



**JC
VALVES**



FIRE SAFE



ISO 9001 : 2015
BUREAU VERITAS
Certification



ISO 14001:2015
BUREAU VERITAS
Certification



PED/2014/68/UE
BUREAU VERITAS
Certification



Certificate 3.1

Size : DN 15 to 200 mm
Ends : PN16/40 R.F. Flanges
Min Temperature : -20°C
Max Temperature : + 230°C
Max Pressure : 40 Bars up to DN50, 16 Bars over
Specifications : ISO 5211 mounting pad
 Fire safe according to ISO 10497 : 2004, API 607
 5th, BS 6755 Part 2 and API 6FA
 Fugitive emissions EN 15848-1:2006 and TALUFT
 ATEX, PTFE filled with 25% glass fiber seat

Materials : Carbon steel ASTM A216 WCB

**2 PIECES BALL VALVE PN16/40 FLANGED JC RANGE
LONG PATTERN (DIN 3202-1 F1)**

SPECIFICATIONS :

- Full bore
- Anti blow-out stem
- PTFE filled with 25% glass fiber seat
- Locking device on request
- ISO 5211 mounting pad
- 2 pieces type (Split body)
- PN40 Flanges R.F. up to DN50, PN16 over
- Antistatic device
- Fire safe ISO 10497 : 2004, API 607 5th, BS 6755 Part.2 and API 6FA
- Fugitive emissions EN 15848-1 : 2006 and TA LUFT VDI 2440
- Graphite packing + FKM O ring on stem
- With exhaust hole in the ball (located in the top of the ball to avoid overpressure in it)

USE :

- Chemical industries, petrochemical industries, hydraulic installation, heating, water distribution, compressed air
- Min and max Temperature Ts : -20°C to + 230°C
- Max Pressure Ps : 40 bars up to DN50, 16 bars over (see graph)
- Vacuum 10⁻² torr
- Compressed air (ambient temperature) : 16 bars maximum
- Steam : 12 bars maximum

PRESSURE / TEMPERATURE GRAPH (STEAM EXCLUDED) :

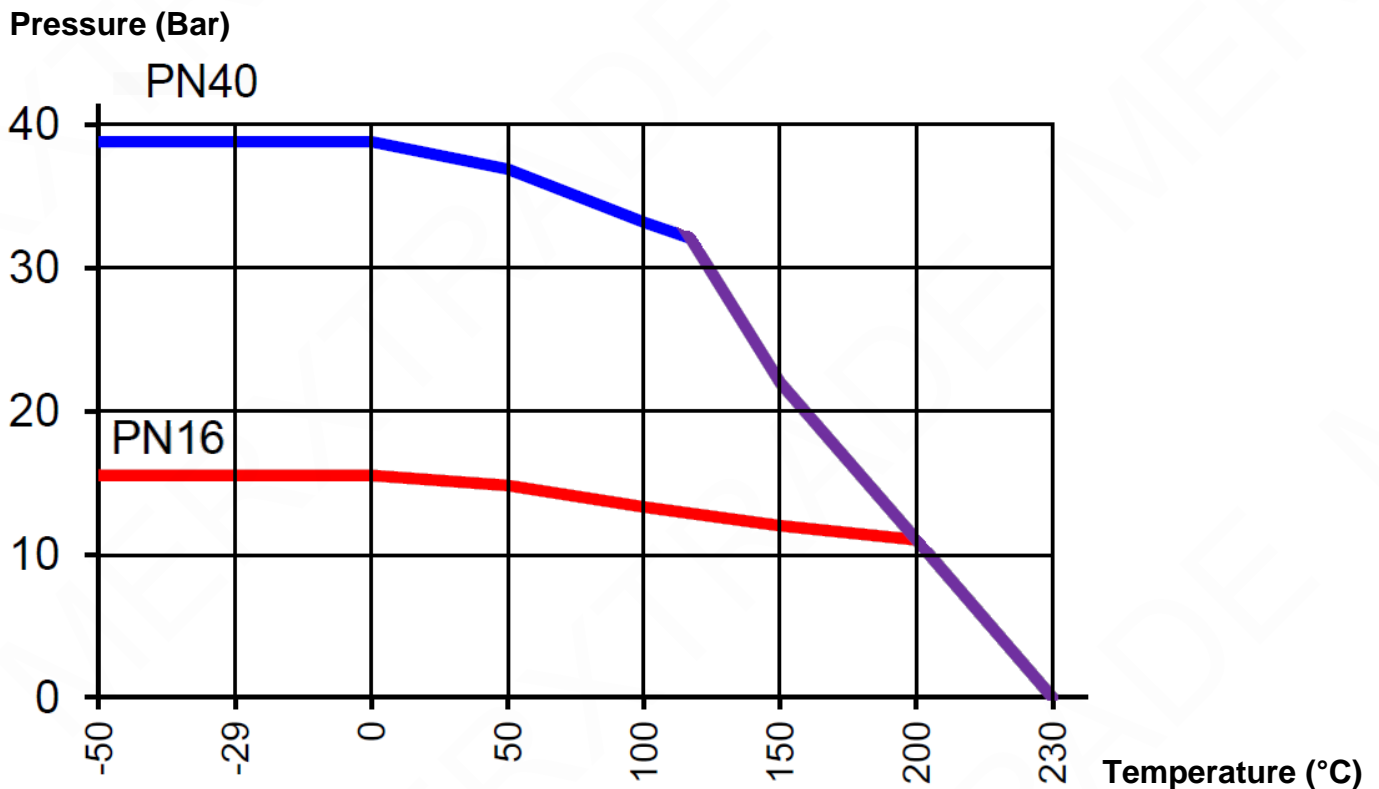

2 PIECES BALL VALVE PN16/40 FLANGED JC RANGE LONG PATTERN (DIN 3202-1 F1)

FLOW COEFFICIENT Kvs (in m³ / h) :

DN	15	20	25	32	40	50	65	80	100	125	150	200
Kvs (m ³ / h)	20	40	75	130	170	270	550	1000	1650	3000	4200	9000

TORQUE VALUE (in Nm without safety coefficient) :

DN	BTO*	RTO	ETO	BTC	RTC	ETC*	MAST	Ps (bars)
15	13,75	7,5	8,75	10	7,5	11,25	26	40
20	17,5	8,75	10	13,75	8,75	13,75	26	40
25	25	12,5	15	18,75	12,5	20	26	40
32	31,25	16,25	18,75	23,75	16,25	25	69	40
40	41,25	21,25	25	31,25	21,25	32,5	85	40
50	57,5	28,75	35	43,75	28,75	46,25	85	40
65	76,25	38,75	46,25	57,5	38,75	61,25	176	16
80	121,25	61,25	72,5	91,25	61,25	97,5	246	16
100	166,25	83,75	100	125	83,75	132,5	305	16
125	282,5	141,25	170	212,5	141,25	226,25	607	16
150	400	200	240	300	200	320	974	16
200	867,5	433,75	520	651,25	433,75	693,75	1387	16

RANGE :

- Carbon steel body ball valve with handle flanged PN40 Ref. **340AIGF** from DN 15 to DN 50
- Carbon steel body ball valve with handle flanged PN16 Ref. **316AIGF** from DN 65 to DN 150
- Carbon steel body ball valve with free stem PN16 Ref. **316AIGF** DN200

ENDS:

- PN40 Flanges R.F. up to DN50, PN16 over

2 PIECES BALL VALVE PN16/40 FLANGED JC RANGE LONG PATTERN (DIN 3202-1 F1)

ACCESSORIES :



- Locking device DN 15-200 Ref.9830130-9830138



- Reinforced locking device DN 15-200 Ref.9830120-9830129



- Stainless steel handle DN 15-150 Ref. 9830513-9830520



- Oval stainless steel handwheel DN 15-50 Ref.9830575-9830577



- Gearbox DN 125-300 Ref. 9830397-9830401



- Single stainless steel stem extension DN 15-200 Ref. 9810615-9810623

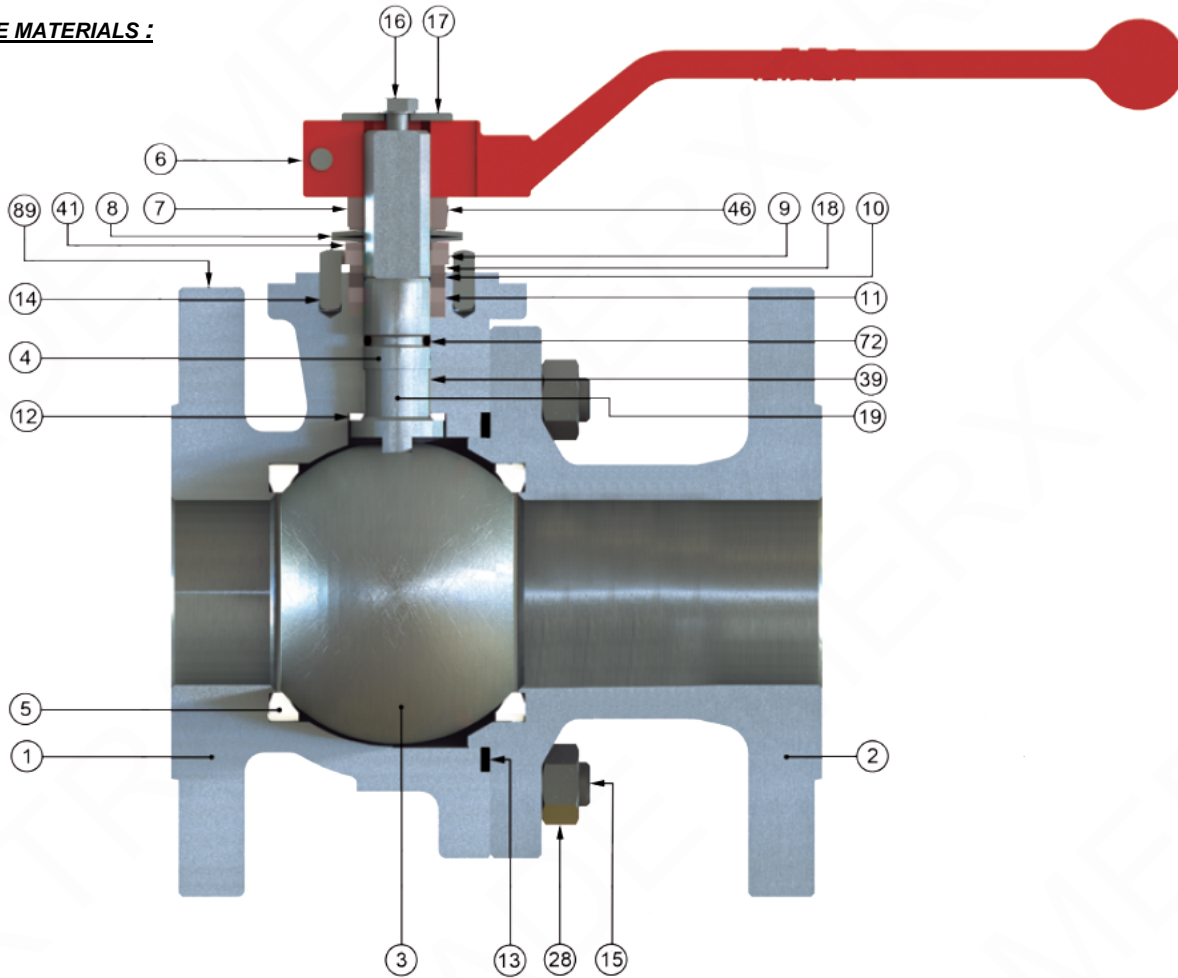

- ISO 5211 carbon steel stem extension DN 15-100 Ref. 9810624-9810627
- ISO 5211 stainless steel stem extension DN 15-100 Ref. 9810628-9810631

**2 PIECES BALL VALVE PN16/40 FLANGED JC RANGE
 LONG PATTERN (DIN 3202-1 F1)**
VALVE MATERIALS :

Item	Designation	Materials	Item	Designation	Materials
1	Body	ASTM A216 WCB 1.0619	13	Body spiral seat	AISI 316L + PTFE + Graphite
2	Ends		14	Pin	Steel
3	Ball DN15-25	ASTM A479 Tp.316	15	Screw (stud DN32-100)	DIN 933 8.8 zinc dichrom.
	Ball DN 32-200	Inox ASTM A 351 CF8M	16	Handle screw	DIN 933 A4-70
4	Stem	ASTM A479 Tp.316	17	Washer	Zinc plated carbon steel
5	Seat	PTFE filled with 25% glass	18	Thrust washer	PTFE filled with 25% glass
6	Handle	Ductile iron	19	Antistatic device	Stainless steel
7	Packing nut	Steel	28	Nut (DN32-100)	DIN 934 8.8 zinc dichrom.
8	Elastic ring	Steel	39	Stem bushing (DN25-200)	PTFE filled with 25% glass
9	Stop washer	Steel	41	Spacer (DN40-200)	Steel
10	Packing gland	AISI 303	46	Washer	AISI 304
11	Packing	Graphite	72	O ring	FKM
12	Gasket	PTFE filled with 25% glass	89	ID plate	Stainless steel

**2 PIECES BALL VALVE PN16/40 FLANGED JC RANGE
LONG PATTERN (DIN 3202-1 F1)**

GEARBOX MATERIALS :

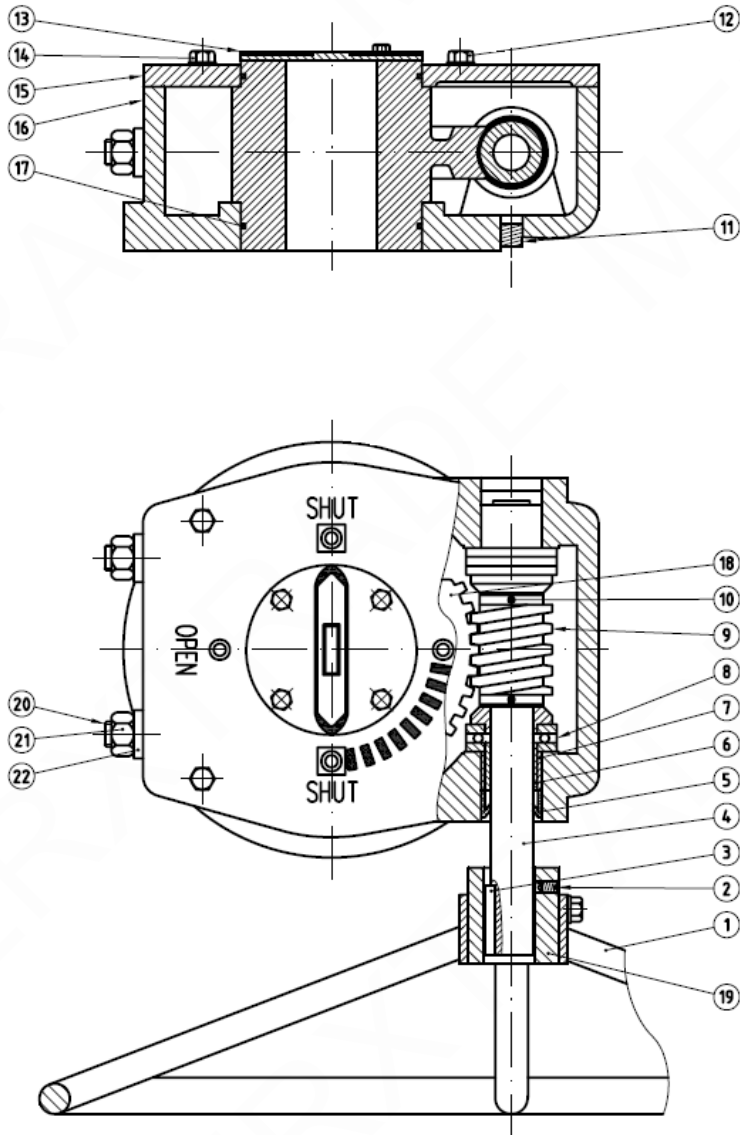

Item	Designation	Materials
1	Handwheel	Carbon steel
2	Screw	
3	Stem key	
4	Input shaft	AISI 1045
5	Oil seal	Rubber
6	Bearing	Cu Base Alloy
7	Oil bearing	
8	Thrust bearing	Carbon steel
9	Worm	AISI 1045
10	Pin	Carbon steel
11	Plug	
12	Screw	Cast iron
13	Indicator plate	
14	Screw	Carbon steel
15	Cover	
16	Housing	Cast iron
17	O ring	
18	Worm gear	Ductile iron
19	Nut	Carbon steel
20	Stop screw	
21	Nut	
22	Hex nut	
23-24	Spur gear cover+housing	Cast iron
25	Seal cover	Rubber
26-27-28	Screw+washer	Carbon steel
29	Gear	
30	Bearing	Cu Base Alloy
31	Bolt	Carbon steel
32	Slotted spring pin	
33	Spur gear	
34	Locator pins	

**2 PIECES BALL VALVE PN16/40 FLANGED JC RANGE
 LONG PATTERN (DIN 3202-1 F1)**

VALVE SIZE (in mm) :

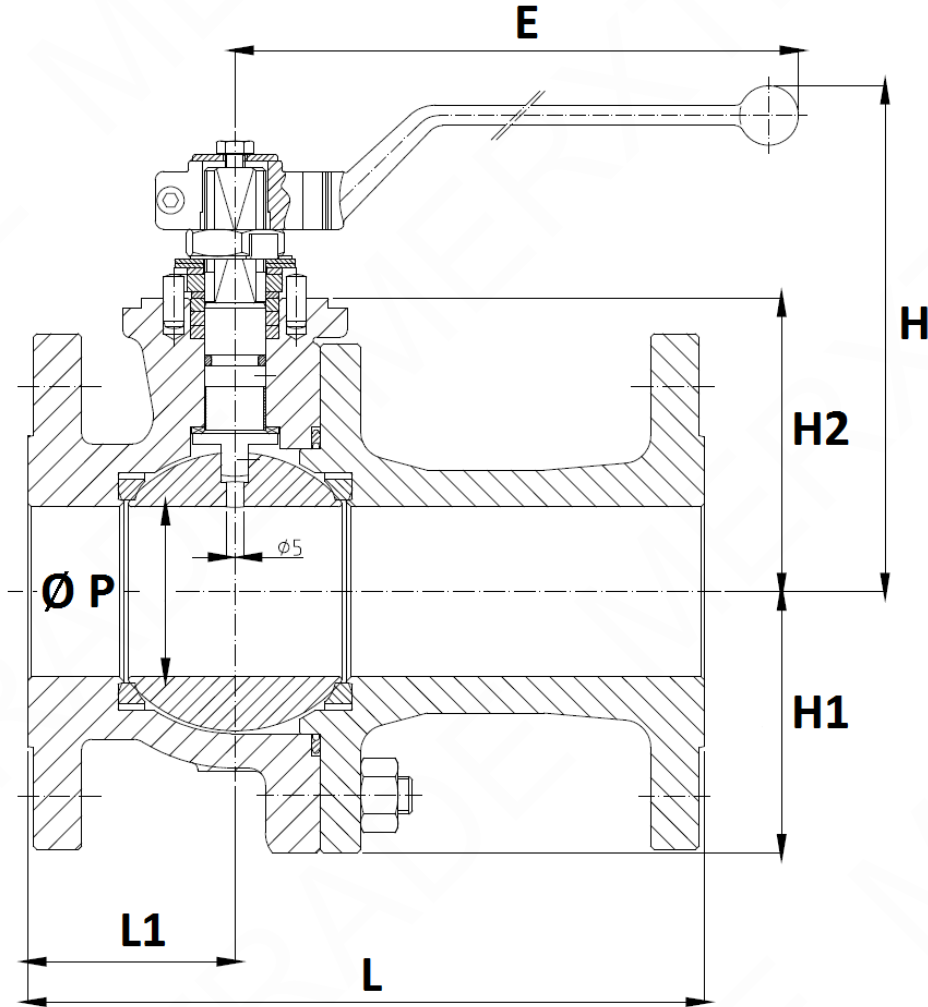

DN	15	20	25	32	40	50	65	80	100	125	150	200*
Ø P	15	20	25	32	40	50	65	80	100	125	151	203
L	130	150	160	180	200	230	290	310	350	400	480	600
L1	53	52	48.5	54	55	61	75.5	82	90.5	120	135	200
E	164	164	164	210	213	213	348	445	495	698	698	868
H	111	118	130	131	148	155	169	207	232	265	298	353
H1	-	-	-	-	-	-	-	-	118	138	160	208
H2	46	53	58	66.5	76	83.5	97	111	133	156	183	233
Weight (Kg)	3	3.8	5.2	7.6	9.6	12.9	18.3	24	36	58	81	-

* Handle on request for DN200 (free stem in standard)

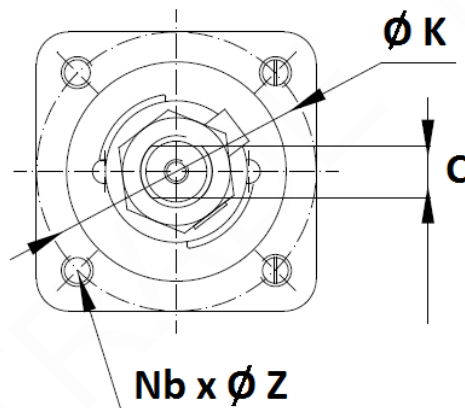
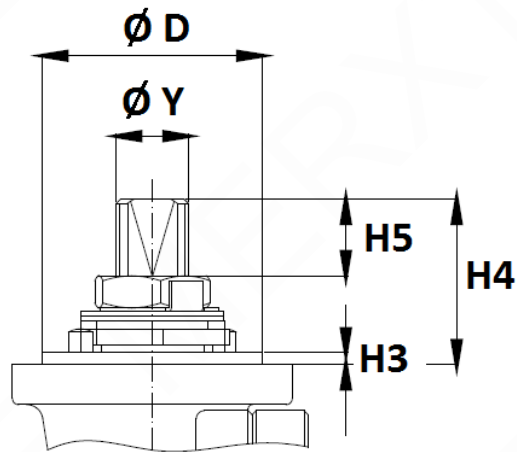
**2 PIECES BALL VALVE PN16/40 FLANGED JC RANGE
 LONG PATTERN (DIN 3202-1 F1)**
ISO MOUNTING PAD AND STEM SIZE (in mm) :

DN	15	20	25	32	40	50	65	80	100	125	150	200
H3	1.5				3							4
H4	11.2	14.7	22.7	32	41.5	41.5	44	44.5	56.5	56	68	72
H5	5	8.5	9.5	13	18.3	18.3	18.6	18.6	27.8	24.7	37.1	36.5
C	9	9	9	12	13	13	16	18	20	25	29	32
Ø Y	M12x1.5			M16x1.5	M18x1.5		M22x1.5	M25x1.5	M28x1.5	M35x2	M40x2	M45x2
Ø D	35				55			70		85		100
Ø K	50	50	50	50	70	70	70	102	102	125	125	140
ISO	F05	F05	F05	F05	F07	F07	F07	F10	F10	F12	F12	F14
N x Ø Z	4 x M6	4 x M6	4 x M6	4 x M6	4 x M8	4 x M8	4 x M8	4 x M10	4 x M10	4 x M12	4 x M12	4 x M16

**2 PIECES BALL VALVE PN16/40 FLANGED JC RANGE
LONG PATTERN (DIN 3202-1 F1)**

GEARBOX SIZE DN125-200 (in mm) :

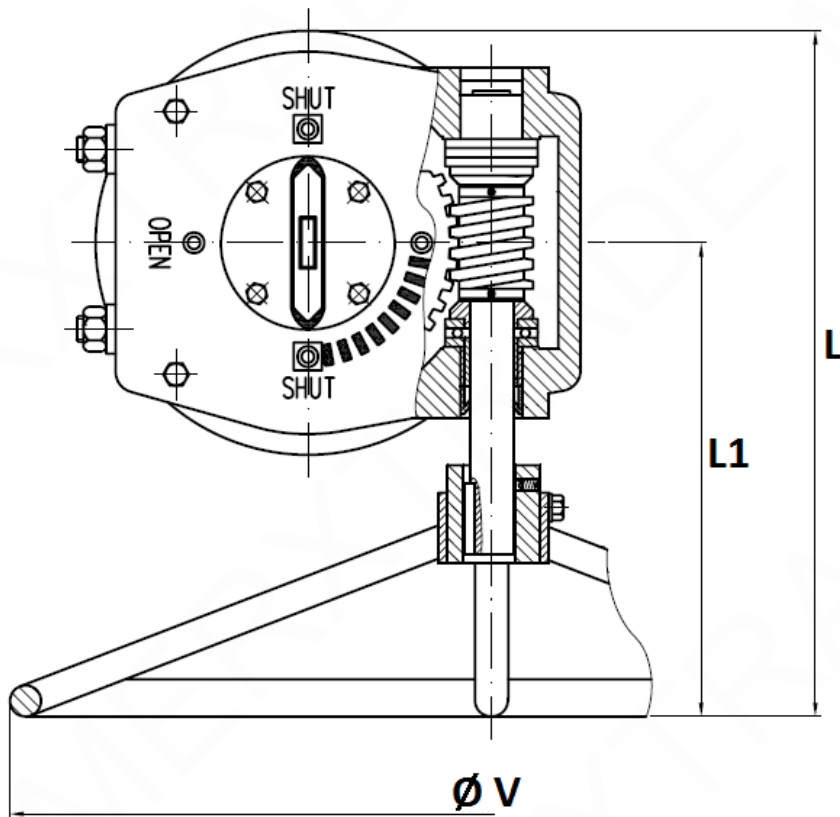
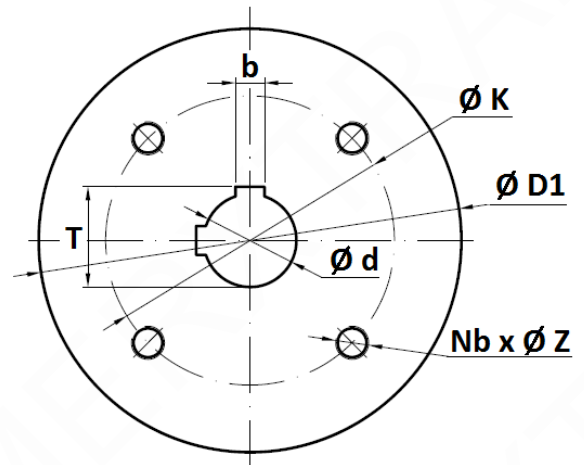
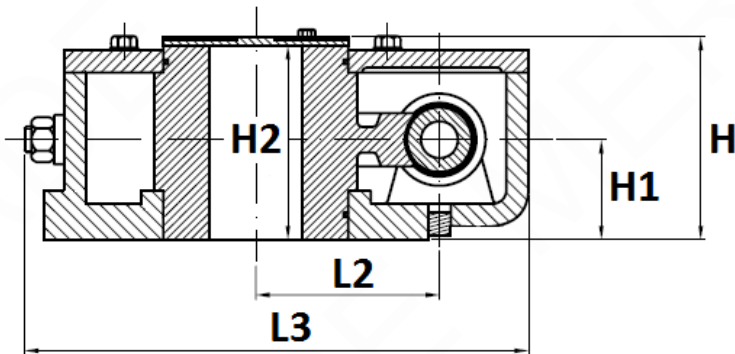

DN	125-150-200
Ø V	465
L	331.5
L1	229
L2	77.5
L3	245
H	107
H1	55
H2	85
Ø d	45
Ø D1	205
Ø K	140
ISO	F14
Nb - Ø Z	4-M16x20
b	14
T	48.6
Weight (in Kg)	17.8
Torque (Nm)	1200

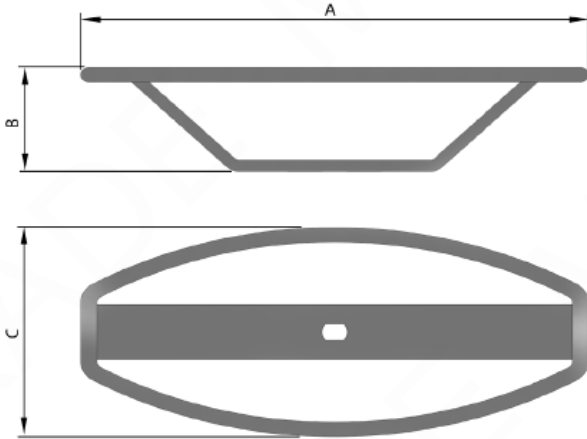
**2 PIECES BALL VALVE PN16/40 FLANGED JC RANGE
 LONG PATTERN (DIN 3202-1 F1)**
OVAL HANDWHEEL SIZE DN15-50 (in mm) :

DN	15	20	25	32	40	50
A	160	160	160	200	216	216
B	54	54	54	56	57	57
C	75	75	75	90	100	100
Weight (Kg)	0.25	0.25	0.25	0.5	0.55	0.55
Ref.	9830575			9830576	9830577	

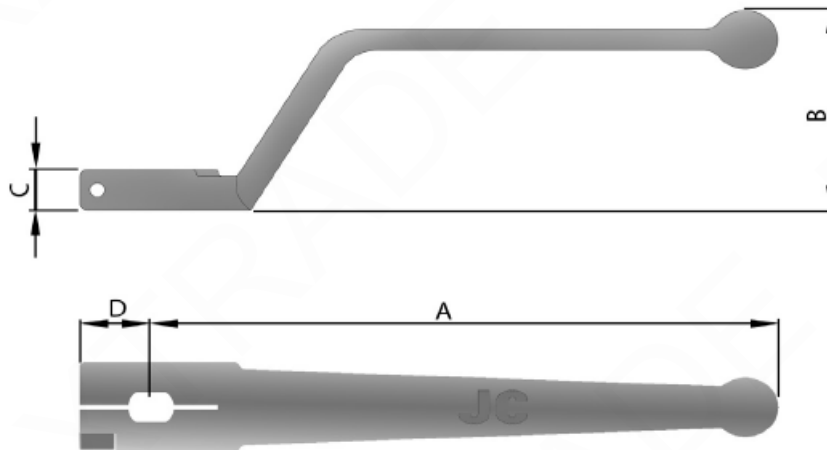
STAINLESS STEEL HANDLE SIZE DN15-200 (in mm) :

DN	15	20	25	32	40	50	65	80	100	125	150	200
A	163.5		300		212.5		347.5	445	495	697.5		867.5
B	58.5		45	48.5		46.5	70	70	77.5	84.5	84.5	
C	12		16	21		20		29	30	40		
D	18.5		22	25.5			33		47		55	
Weight (Kg)	0.2		0.3	0.53		0.63	1.52	1.85	2.95	3.4	4.6	
Ref.	9830513		9830514	9830515		9830516	9830517	9830518	9830519	9830520		

**2 PIECES BALL VALVE PN16/40 FLANGED JC RANGE
LONG PATTERN (DIN 3202-1 F1)**

SINGLE STAINLESS STEEL STEM EXTENSION SIZE DN15-200 (in mm) :



DN	15	20	25	32	40	50	65	80	100	125	150	200
A	100											
Weight (Kg)	0.25		0.57		0.56		0.78	1.03	1.42	1.67	2.25	2.97
Ref.	9810615		9810616		9810617		9810618	9810619	9810620	9810621	9810622	9810623

STANDARD ISO 5211 STEM EXTENSION (CARBON AND STAINLESS STEEL) DN15-100 (mm) :

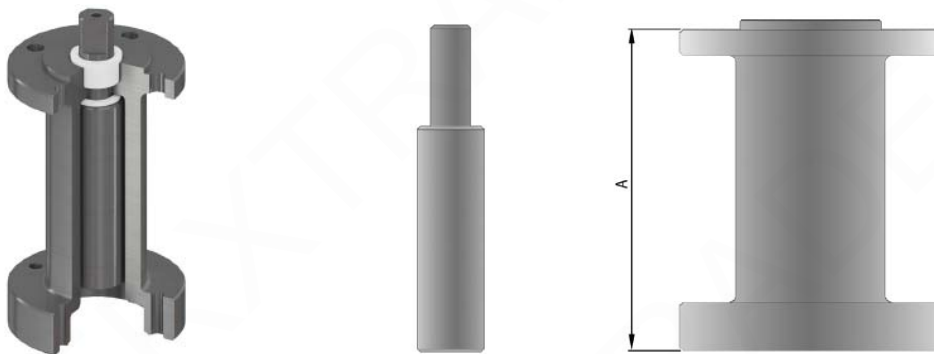

DN	15	20	25	40	50	80	100
A	100						
Weight (Kg)	1.24			2.63		4.78	4.18
Ref. Steel	9810624			9810625		9810626	9810627
Ref. St.steel	9810628			9810629		9810630	9810631

**2 PIECES BALL VALVE PN16/40 FLANGED JC RANGE
LONG PATTERN (DIN 3202-1 F1)**

FLANGES SIZE (in mm) :

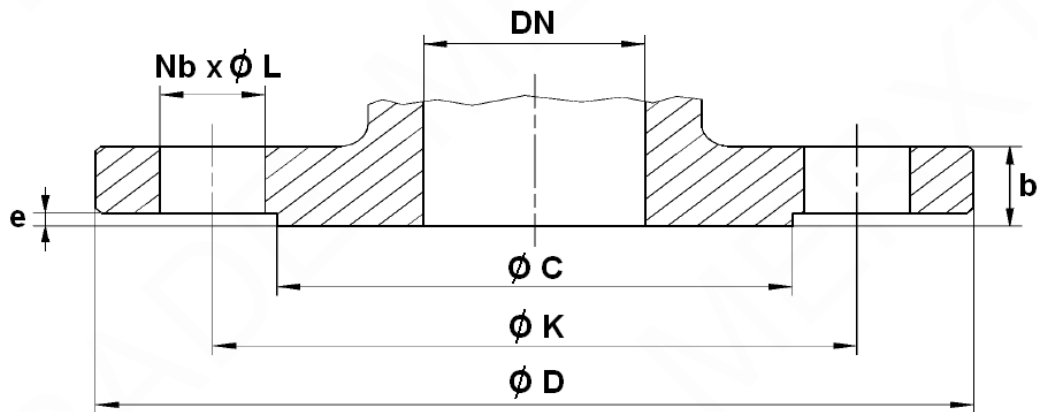

DN	15	20	25	32	40	50	65	80	100	125	150	200
Ø C	45	58	68	78	88	102	122	138	158	188	212	268
Ø D	95	105	115	140	150	165	185	200	220	250	285	340
Ø K	65	75	85	100	110	125	145	160	180	210	240	295
Nb x Ø L	4 x 14	4 x 14	4 x 14	4 x 18	4 x 18	4 x 18	4 x 18	8 x 18	8 x 18	8 x 18	8 x 22	12 x 22
b	16	18	18	18	18	20	18	20	20	22	22	24
e	2	2	2	2	3	3	3	3	3	3	3	3

**2 PIECES BALL VALVE PN16/40 FLANGED JC RANGE
LONG PATTERN (DIN 3202-1 F1)**

STANDARDS :

- Fabrication according to ISO 9001:2015 and ISO 14001 : 2015
- DIRECTIVE 2014/68/EU : CE N° 0056
Risk Category IV module H1
- Certificate 3.1 on request
- Valve designing according to EN 1983 – ISO 17292 and EN 12516
- Pressure Tests according to EN 12266-1, Rate A
- Marking according to EN 19
- Fire safe according to ISO 10497 : 2004, API 607 5th, BS6755 Part 2, and API 6FA 1994
- Fugitive Emissions according to EN 15848-1 : 2006 B Class and TA LUFT VDI 2440
- SIL2 according to IEC/EN 61508, SIL 3 possible according to the type of installation
- Flanges R.F. type B1 according to EN 1092-1 PN16/40
- ISO 5211 mounting pad
- Length according to EN 558 series 1 (long pattern DIN 3202-1 F1)
- ATEX Group II Category 2 G/2Dc Zone 1 & 21 Zone 2 & 22 (optional marking) up to DN200 according to directive 2014/34/EU
- Russian certificate TRCU 10, TRCU 12 and TRCU 32 (EAC marking and declaration **on request**)

ADVICE : Our opinion and our advice are not guaranteed and MXT shall not be liable for the consequences of damages. The customer must check the right choice of the products with the real service conditions.

2 PIECES BALL VALVE PN16/40 FLANGED JC RANGE LONG PATTERN (DIN 3202-1 F1)
--

INSTALLATION INSTRUCTIONS

GENERAL GUIDELINES :

- Ensure that the valves to be used are appropriate for the conditions of the installation (type of fluid, pressure and temperature).
- Be sure to have enough valves to be able to isolate the sections of piping as well as the appropriate equipment for maintenance and repair.
- Ensure that the valves to be installed are of correct strength to be able to support the capacity of their usage.
- **Installation of all circuits should ensure that their function can be automatically tested on a regular basis (at least two times a year).**

INSTALLATION INSTRUCTIONS :

- **Before installing the valves, clean and remove any objects from the pipes** (in particular bits of sealing and metal) which could obstruct and block the valves.
- **Ensure that both connecting pipes either side of the valve (upstream and downstream) are aligned (if they're not, the valves may not work correctly).**
- **Make sure that the two sections of the pipe (upstream and downstream) match, the valve unit will not absorb any gaps. Any distortions in the pipes may affect the tightness of the connection, the working of the valve and can even cause a rupture.** To be sure, place the kit in position to ensure the assembling will work.
- **If sections of piping do not have their final support in place, they should be temporarily fixed. This is to avoid unnecessary strain on the valve.**
- Tighten the bolts in cross.
- It's recommended to operate the valve (open and close) 1 to 2 times per year